

100G QSFP28 Direct Attach Cable(DAC)



General Description

QSFP28 Direct Attach Cables are compliant with the SFF-8665 specifications. Various choices of wire gauge are available from 30 to 26 AWG with various choices of cable length (up to 5m).

Features

- Compliant with SFF- 8665
- Up to 28.3125Gbps data rate per channel
- Up to 5m transmission
- Operating temperature: 0~70°C
- Single 3.3V power supply
- RoHS compliant

Benefits

- Cost-effective copper solution
- Lowest total system power solution
- Lowest total system EMI solution
- Optimized design for Signal Integrity

Applications

- 100G Ethernet

Pin Function Definition

Pin	Logic	Symbol	Description
1		GND	Ground
2	CML-I	Tx2n	Transmitter Inverted Data Input
3	CML-I	Tx2p	Transmitter Non-Inverted Data Input
4		GND	Ground
5	CML-I	Tx4n	Transmitter Inverted Data Input
6	CML-I	Tx4p	Transmitter Non-Inverted Data Input
7		GND	Ground
8	LVTTL-I	ModSelL	Module Select
9	LVTTL-I	ResetL	Module Reset
10		Vcc Rx	+3.3V Power Supply Receiver
11	LVC MOS-I/O	SCL	2-wire serial interface clock
12	LVC MOS-I/O	SDA	2-wire serial interface data
13		GND	Ground
14	CML-O	Rx3p	Receiver Non-Inverted Data Output
15	CML-O	Rx3n	Receiver Inverted Data Output
16		GND	Ground

17	CML-O	Rx1p	Receiver Non-Inverted Data Output
18	CML-O	Rx1n	Receiver Inverted Data Output
19		GND	Ground
20		GND	Ground
21	CML-O	Rx2n	Receiver Inverted Data Output
22	CML-O	Rx2p	Receiver Non-Inverted Data Output
23		GND	Ground
24	CML-O	Rx4n	Receiver Inverted Data Output
25	CML-O	Rx4p	Receiver Non-Inverted Data Output
26		GND	Ground
27	LVTTL-O	ModPrsL	Module Present
28	LVTTL-O	IntL	Interrupt
29		Vcc Tx	+3.3V Power supply transmitter
30		Vcc1	+3.3V Power supply
31	LVTTL-I	LPMode	Low Power Mode
32		GND	Ground
33	CML-I	Tx3p	Transmitter Non-Inverted Data Input
34	CML-I	Tx3n	Transmitter Inverted Data Input
35		GND	Ground
36	CML-I	Tx1p	Transmitter Non-Inverted Data Input
37	CML-I	Tx1n	Transmitter Inverted Data Input
38		GND	Ground

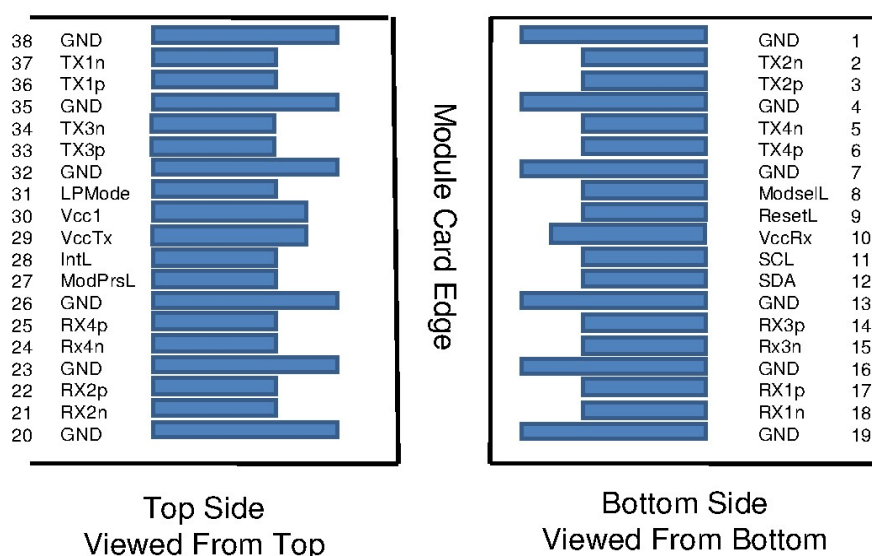

General Product Characteristics

QSFP+ DAC Specifications	
Number of Lanes	Tx & Rx
Channel Data Rate	28.3125 Gbps
Operating Temperature	0 to + 70°C
Storage Temperature	-40 to + 85°C
Supply Voltage	3.3 V nominal
Electrical Interface	38 pins edge connector
Management Interface	Serial, I ² C

High Speed Characteristics

Parameter	Symbol	Min	Typ	Max	Units	Notes
Differential Impedance	Zd	90	100	110	Ω	
Differential Input Return Loss	SDDXX	$< -12 + 2 * \text{SQRT}(f)$ with f in GHz			dB	0.01~4.1GHz
		$< -6.3 + 13 * \text{Log}_{10}(f/5.5)$ with f in GHz			dB	4.1~19GHz
Common Mode Output Return Loss	SCCXX	$< -7 + 1.6 * f$ with f in GHz			dB	0.01~12.89GHz
				-3	dB	12.89~19GHz
Difference Waveform Distortion Penalty	dWDPc			6.75	dB	
VMA Loss	L			4.4	dB	
VMA Loss to Crosstalk Ratio	VCR	32.5			dB	

Mechanical Specifications

The connector is compatible with the SFF-8665 specification.

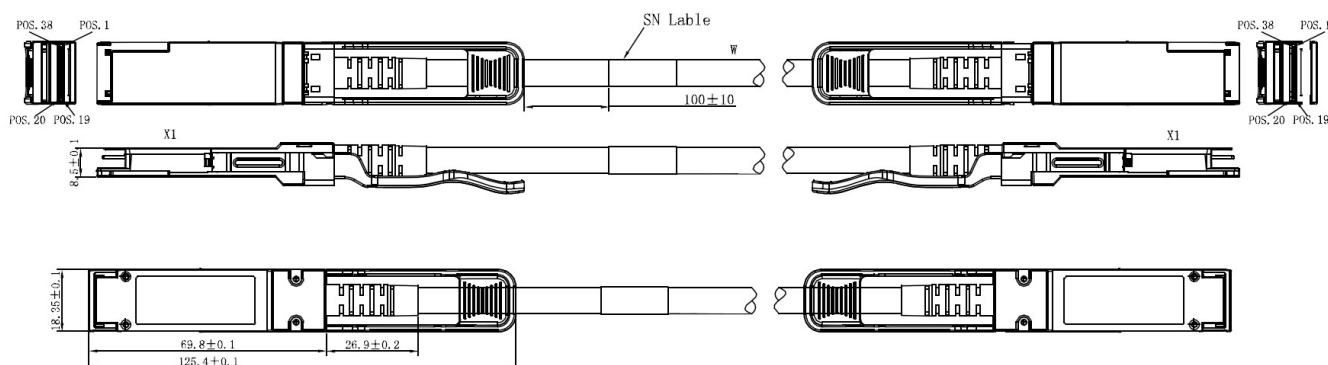

Length (m)	Cable AWG
1	30
2	30
3	30
5	26

Regulatory Compliance

Feature	Test Method	Performance
Electrostatic Discharge (ESD) to the Electrical Pins	MIL-STD-883C Method 3015.7	Class 1(>2000 Volts)
Electromagnetic Interference(EMI)	FCC Class B	Compliant with Standards
	CENELEC EN55022 Class B	
	CISPR22 ITE Class B	
RF Immunity(RFI)	IEC61000-4-3	Typically Show no Measurable Effect from a 10V/m Field Swept from 80 to 1000MHz
RoHS Compliance	RoHS Directive 2011/65/EU and it's Amendment Directives 6/6	RoHS 6/6 compliant