

TS-XFP-LR

10Gbps XFP Optical Transceiver, 10km Reach

Features

- Supports 9.95Gb/s to 11.3Gb/s Bit Rates
- Hot-pluggable XFP Footprint
- Maximum Link Length up to 10km
- 1310nm DFB laser and PIN photodiode
- Duplex LC Connector
- Power Dissipation <2.5W
- Built-in Digital Diagnostic Functions
- Operating Case Temperature Standard : 0°C to +70°C
- Complaint with XFP MSA
- Complaint with IEEE 802.3ae 10GBASE-LR/LW
- Complaint with 10GFC 1200-SM-LL-L



Applications

- SONET OC-192 SR-1, SDH STM I-64.1 at 9.953Gbps
- 10GBASE-LR/LW 10G Ethernet
- 1200-SM-LL-L 10G Fiber Channel
- 10GE over G.709 at 11.09Gbps
- OC192 over FEC at 10.709Gbps

Description

TS-XFP-LR is compliant with the 10G Small Form-Factor Pluggable (XFP) Multi-Source Agreement (MSA), supporting data-rate of 10.3125Gbps(10GBASE-LR) or 9.953Gbps 10GBASE-LW), and transmission distance up to 10km on SMF.

The transceiver module comprises a transmitter with 1310nm DFB laser and a receiver with a PIN photodiode. Transmitter and receiver are separate within a wide temperature range of 0°C to +70°C and offers optimum heat dissipation and excellent electromagnetic shielding thus enabling high port densities for 10GbE systems. The receiver section uses an integrated InGaAs detector preamplifier (IDP) mounted in an optical header and a limiting post-amplifier IC.

Absolute Maximum Ratings^{*Note}

Parameter	Symbol	Min	Max	Unit
Supply Voltage Range @ 3.3V	Vcc3	-0.5	4.0	V
Supply Voltage Range @ 5V	Vcc5	-0.5	6.0	V
Operating Relative Humidity	RH		80	%
Storage Temperature	Ts	-40	+85	°C

Note: Exceeding any one of these values may destroy the device permanently.

Recommended Operating Conditions

Parameter	Symbol	Min	Typical	Max	Unit
Operating Case Temperature	Tc	0		+70	°C
Power Supply Voltage @ 3.3V	Vcc3	3.13	3.3	3.45	V
Power Supply Voltage @ 5V	Vcc5	4.75	5	5.25	V
Module total power	P			2.5	W

Electrical Characteristics

Parameter	Symbol	Min	Typical	Max	Unit	Notes	
Power Supply Voltage @ 5V	Vcc5	4.75		5.25	V		
Power Supply Voltage @ 3.3V	Vcc3	3.13		3.47	V		
Module Total Power	P			2.5	W		
Transmitter							
Input differential impedance	Rin		100		Ω	1	
Differential Data Input Swing	Vin,pp	120		820	mV		
Transmit Disable Voltage	V _D	2.0		Vcc	V		
Transmit Enable Voltage	V _{EN}	GND		GND+ 0.8	V		
Transmit Disable Assert Time				10	us		
Receiver							
Differential Data Output Swing	Vout,pp	500		850	mV		
Rise Time (20– 80%)	tr			38	ps		
Fall Time (20– 80%)	tf			38	ps		
LOS Fault	V _{LOS fault}	Vcc -0.5		VccHOST	V	2	
LOS Normal	V _{LOS norm}	GND		GND+0.5	V	2	
Power Supply Rejection	PSR	See Note 3 below					3

Note1: After internal AC coupling

Note2: Loss Of Signal is open collector to be pulled up with a 4.7k~10kohm resistor to 3.15~3.6V. Logic 0 indicates normal operation; logic 1 indicates no signal detected.

Note3: Per Section 2.7.1.1 in the XFP MSA Specification.

Optical Characteristics

Parameter	Symbol	Min	Typical	Max	Unit
Transmitter					
Centre Wavelength	λ_c	1260		1355	nm
Side Mode Suppression Ratio	SMSR	30			nm
Average Output Power	P_{out}	-6		-1	dBm
Extinction Ratio ^{*Note1}	ER	6			dB
Average Launch power of OFF transmitter	POFF	-30			dBm
Tx Jitter	Tx_j	Compliant with each standard requirements			
Receiver					
Centre Wavelength	λ_c	1260		1600	nm
Receiver Sensitivity ^{*Note2}	P_{min}			-13	dBm
Receiver Sensitivity in OMA ^{*Note2}	RSSENS			-11	
Receiver Overload	P_{MAX}	0.5			dBm
LOS De-Assert	LOS_D			-14	dBm
LOS Assert	LOS_A	-25			dBm
LOS Hysteresis		1		4	dB

Note1: PRBS 2 31 -1 test pattern @10.3125Gbps.

Note2: PRBS 2 31 -1 test pattern @10.3125Gbps, BER $\leq 10^{-12}$

Pin Descriptions

Pin	Logic	Symbol	Name/Description	Note
1		GND	Module Ground	1
2		VEE5	Optional -5.2V Power Supply (Not required)	
3	LVTTL-I	MOD_DESEL	Module De-select; When held low allows the module to respond to 2-wire serial interface	
4	LVTTL-O	INTb	Interrupt; Indicates presence of an important condition which can be read via the 2-wire serial interface	2
5	LVTTL-I	TX_DIS	Transmitter Disable; Turns off transmitter laser output	
6		VCC5	+5V Power Supply	
7		GND	Module Ground	1
8		VCC3	+3.3V Power Supply	
9		VCC3	+3.3V Power Supply	
10	LVTTL-I/O	SCL	2-Wire Serial Interface Clock	2
11	LVTTL-I/O	SDA	2-Wire Serial Interface Data Line	2
12	LVTTL-O	MOD_Abs	Indicates Module is not present. Grounded in the Module	2
13	LVTTL-O	MOD_NR	Module Not Ready; Indicating Module Operational Fault	2
14	LVTTL-O	RX_LOS	Receiver Loss Of Signal Indicator	2

15		GND	Module Ground	1
16		GND	Module Ground	1
17	CML-O	RDN	Receiver Inverted Data Output	
18	CML-O	RDP	Receiver Non-Inverted Data Output	
19		GND	Module Ground	1
20		VCC2	+1.8V Power Supply (Not required).	3
21	LVTTTL-I	P_DOWN/RST	Power down; When high, requires the module to limit power consumption to 1.5W or below. 2-Wire serial interface must be functional in the low power mode.	
			Reset; The falling edge initiates a complete reset of the module including the 2-wire serial interface, equivalent to a power cycle.	
22		VCC2	+1.8V Power Supply (Not required)	3
23		GND	Module Ground	1
24	PECL-I	REFCLKP	Not used, internally terminated to 50ohm (100ohm diff).	4
25	PECL-I	REFCLKN	Not used, internally terminated to 50ohm (100ohm diff).	4
26		GND	Module Ground	1
27		GND	Module Ground	1
28	CML-I	TDN	Transmitter Inverted Data Input	
29	CML-I	TDP	Transmitter Non-Inverted Data Input	
30		GND	Module Ground	1

Notes:

1. Module ground pins GND are isolated from the module case and chassis ground within the module.
2. Open collector; shall be pulled up with 4.7K-10Kohms to a voltage between 3.15V and 3.6V on the host board.
3. The pins are open within module.
4. Reference Clock is not required.

Host board Connector Pin out

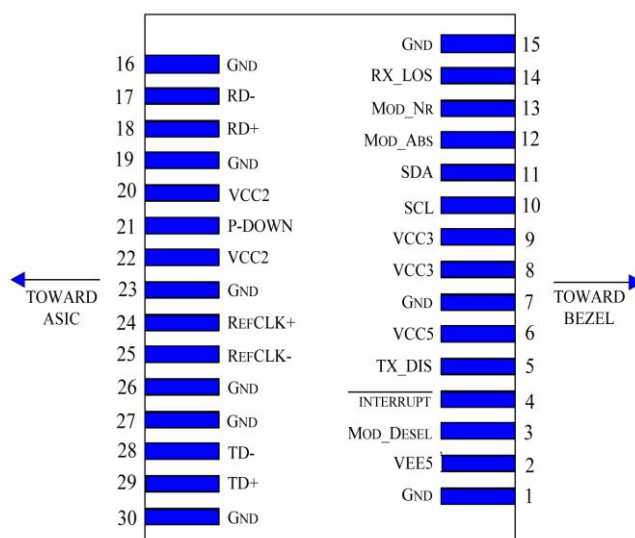

Management Interface

The transceivers provide serial ID memory contents and diagnostic information about the present operating conditions by the 2-wire serial interface (SCL, SDA).

The Module provides diagnostic information about the present operating conditions. The transceiver generates this diagnostic data by digitization of internal analog signals. Alarm/warning threshold data is written during device manufacture. Received power monitoring, transmitted power monitoring, bias current monitoring, supply voltage monitoring and temperature monitoring all are implemented.

The digital diagnostic memory map specific data field defines as following.

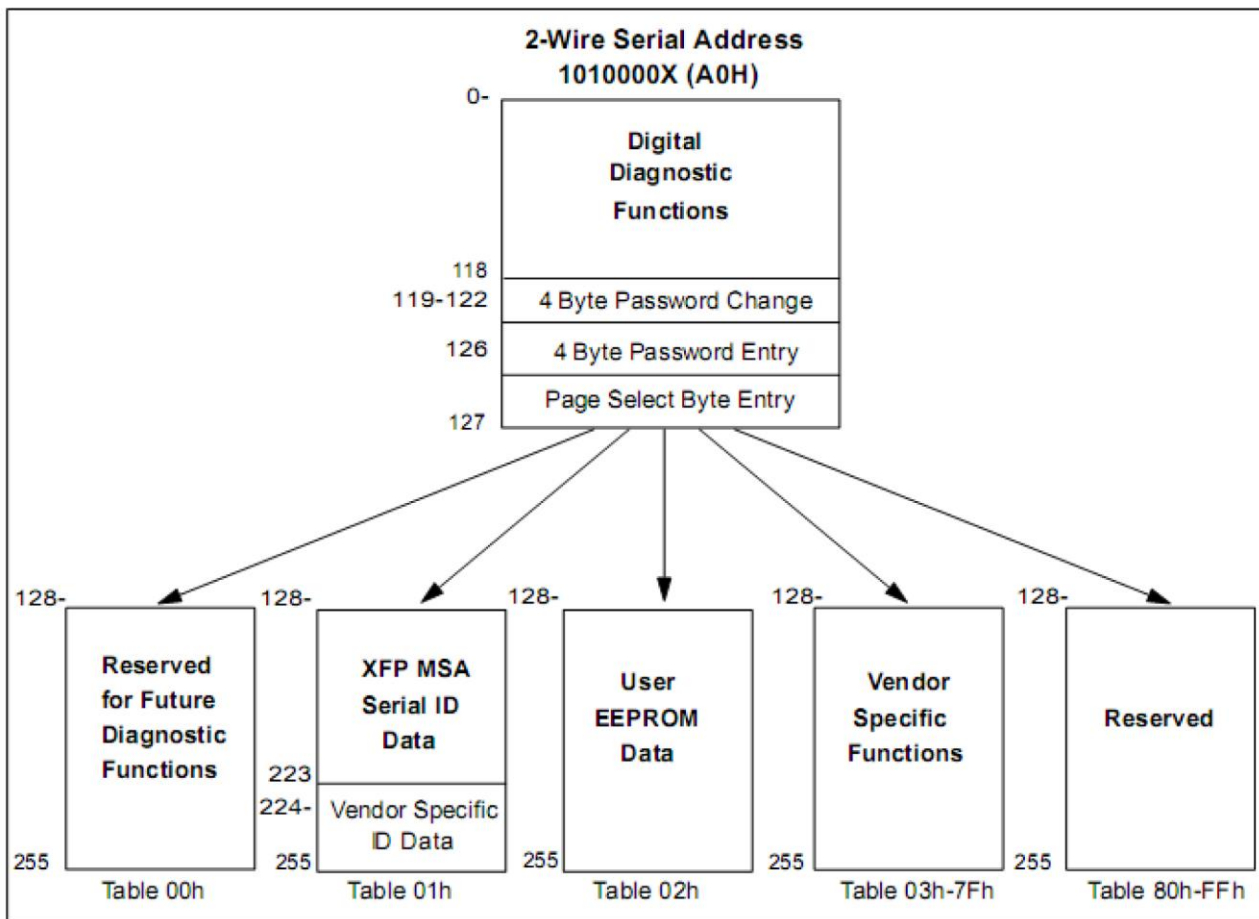

Recommended Host Board Power Supply Circuit

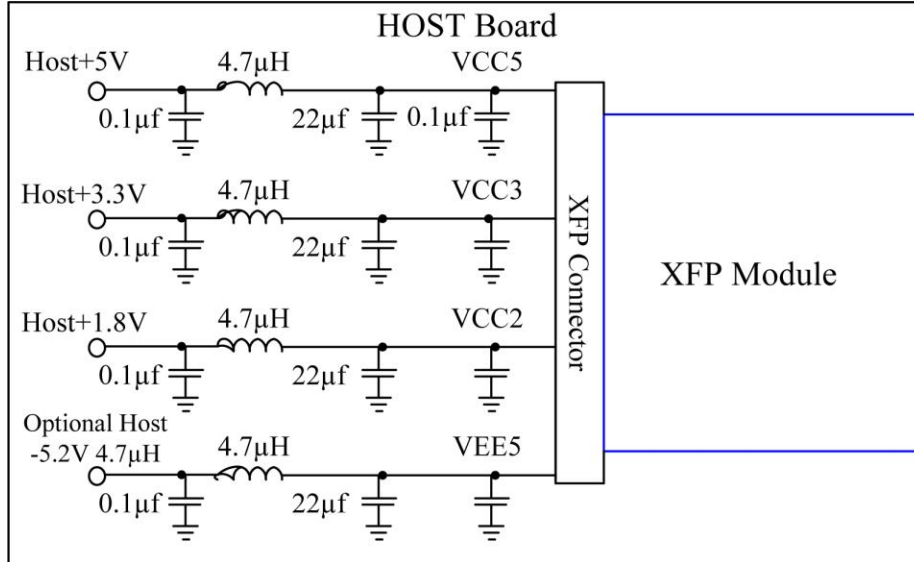

Recommended High-speed Interface Circuit

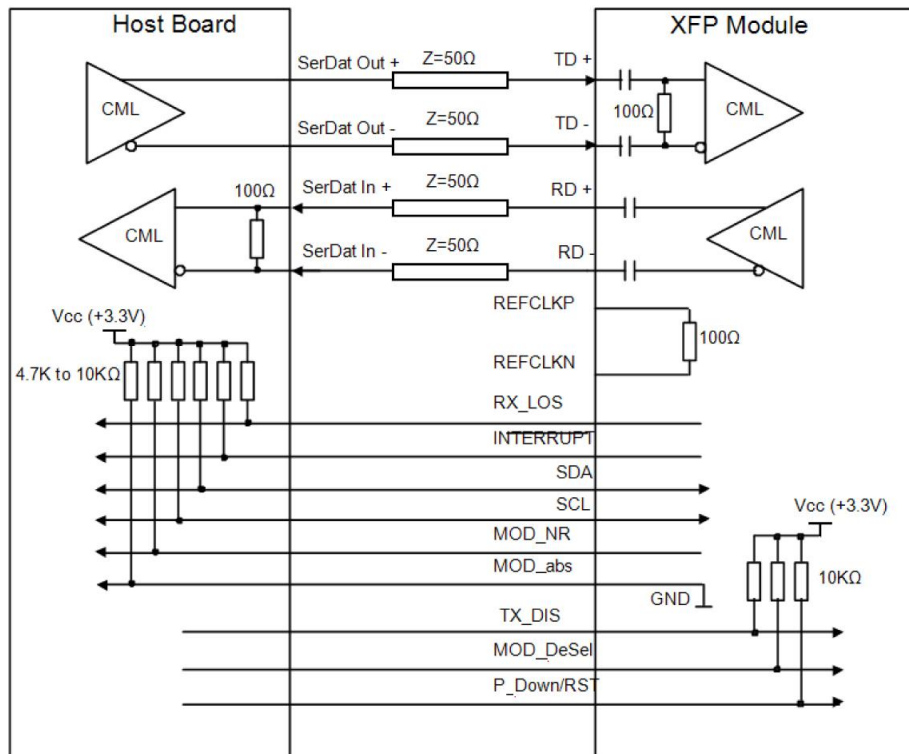

Package Dimensions

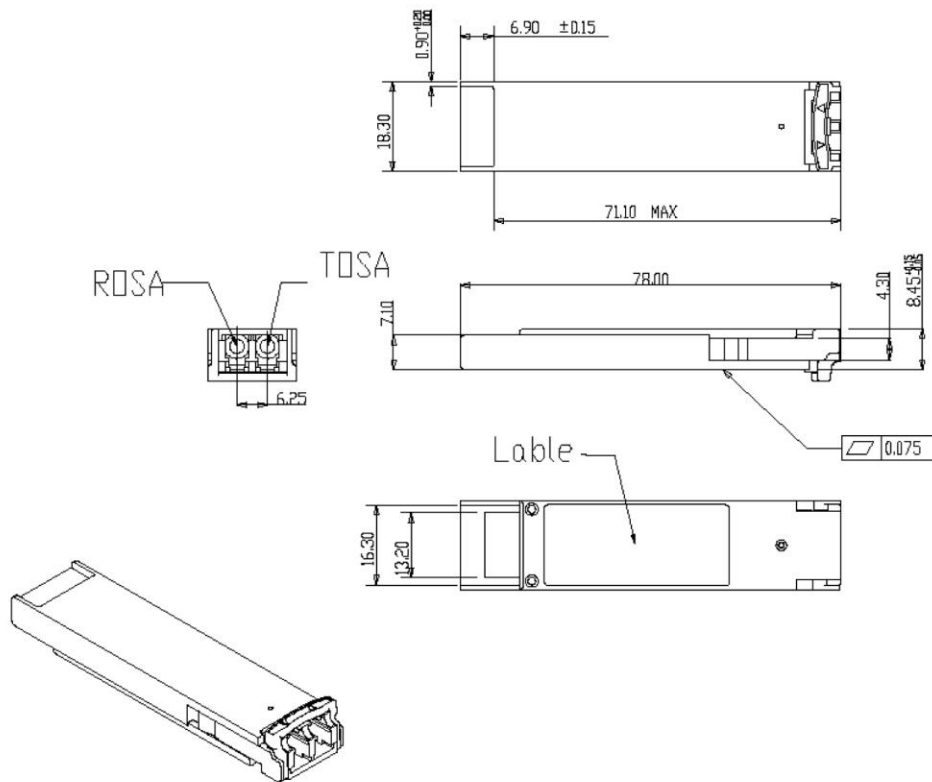

Eye Safety

This single-mode transceiver is a Class 1 laser product. It complies with IEC-60825 and FDA 21 CFR 1040.10 and 1040.11. The transceiver must be operated within the specified temperature and voltage limits. The optical ports of the module shall be terminated with an optical connector or with a dust plug.

Regulatory Compliance

Feature	Standard	Performance
Electrostatic Discharge (ESD) to the Electrical Pins	MIL-STD-883G Method 3015.7	Class 1C (>1000 V)
Electrostatic Discharge to the enclosure	EN 55024:1998+A1+A2 IEC-61000-4-2 GR-1089-CORE	Compliant with standards
Electromagnetic Interference (EMI)	FCC Part 15 Class B EN55022:2006 CISPR 22B :2006 VCCI Class B	Compliant with standards Noise frequency range: 30 MHz to 6 GHz. Good system EMI design practice required to achieve Class B margins. System margins depend on customer host board and chassis design.
Immunity	EN 55024:1998+A1+A2 IEC 61000-4-3	Compliant with standards. 1kHz sine-wave, 80% AM, from 80 MHz to 1 GHz. No effect on transmitter/receiver performance is detectable between these limits.
Laser Eye Safety	FDA 21CFR 1040.10 and 1040.11 EN (IEC) 60825-1:2007 EN (IEC) 60825-2:2004+A1	CDRH compliant and Class I laser product. TüV Certificate No. 50135086
Component Recognition	UL and CUL EN60950-1:2006	UL file E317337 TüV Certificate No. 50135086 (CB scheme)
RoHS6	2002/95/EC 4.1&4.2 2005/747/EC 5&7&13	Compliant with standards ^{*note}

Note:

In light of item 5 in RoHS exemption list of RoHS Directive 2002/95/EC, Item 5: Lead in glass of cathode ray tubes, electronic components and fluorescent tubes.

In light of item 13 in RoHS exemption list of RoHS Directive 2005/747/EC, Item 13: Lead and cadmium in optical and filter glass. The three exemptions are being concerned for TONGSION's transceivers, because TONGSION's transceivers use glass, which may contain Pb, for components such as lenses, isolators, and other electronic components.

Ordering information

Part Number	Product Description
TS-XFP-LR	1310nm, 10Gbps, LC, 10km, 0°C~+70°C, With DDM

Important Notice

Performance figures, data and any illustrative material provided in this data sheet are typical and must be specifically confirmed in writing by TONGSION before they become applicable to any particular order or contract. In accordance with the TONGSION policy of continuous improvement specifications may change without notice.

The publication of information in this data sheet does not imply freedom from patent or other protective rights of TONGSION or others. Further details are available from any TONGSION sales representative.

Contact:

sales@tongsion.com

<http://www.tongsion.com>